

## » NOVOS Touch RS485 Modbus

Room operating unit temperature, optional with humidity | CO2 | VOC

**thermokon**<sup>®</sup>  
HOME OF SENSOR TECHNOLOGY

### Datasheet

Subject to technical alteration  
Issue date: 02.02.2021 • A112

novos



### » APPLICATION

Room control unit with room temperature measurement, optional humidity, CO2 or VOC and a monitoring function for colourful visualization of the measured values. The maintenance-free sensor creates the conditions for a pleasant indoor climate and well-being. Typical applications are schools, office buildings, hotels or cinemas. The room control unit has a high-resolution 4.8" display. The innovative and self-explanatory operation offers the functions of light, shading, climate and scene control for intelligent room automation.

### » TYPES AVAILABLE

**Touch screen room operating unit temperature + opt. humidity, CO2, VOC – active BUS**

NOVOS Touch Temp RS485 Modbus  
NOVOS Touch Temp\_rH RS485 Modbus  
NOVOS Touch CO2\_Temp\_rH RS485 Modbus  
NOVOS Touch VOC\_Temp\_rH RS485 Modbus  
NOVOS Touch CO2+VOC\_Temp\_rH RS485 Modbus

### » SECURITY ADVICE – CAUTION



The installation and assembly of electrical equipment should only be performed by authorized personnel.

The product should only be used for the intended application. Unauthorised modifications are prohibited! The product must not be used in relation with any equipment that in case of a failure may threaten, directly or indirectly, human health or life or result in danger to human beings, animals or assets. Ensure all power is disconnected before installing. Do not connect to live/operating equipment.

Please comply with

- Local laws, health & safety regulations, technical standards and regulations
- Condition of the device at the time of installation, to ensure safe installation
- This data sheet and installation manual

## » NOTES ON DISPOSAL



As a component of a large-scale fixed installation, Thermokon products are intended to be used permanently as part of a building or a structure at a pre-defined and dedicated location, hence the Waste Electrical and Electronic Act (WEEE) is not applicable. However, most of the products may contain valuable materials that should be recycled and not disposed of as domestic waste. Please note the relevant regulations for local disposal.

## » REMARKS TO ROOM SENSORS

### Location and Accuracy of Room Sensors

The room sensor should be mounted in a suitable location for measuring accurate room temperature. The accuracy of the temperature measurement also depends directly on the temperature dynamics of the wall. It is important, that the back plate is completely flush to the wall so that the circulation of air occurs through the vents in the cover. Otherwise, deviations in temperature measurement will occur due to uncontrolled air circulation. Also the temperature sensor should not be covered by furniture or similar devices. Mounting next to doors (due to draught) or windows (due to colder outside wall) should be avoided. The temperature dynamics of the wall will influence the temperature measurement. Various wall types (brick, concrete, dividing and hollow brickwork) all have different behaviours with regards to thermal variations.

### Surface and Flush Mounting

The temperature dynamics of the wall influence the measurement result of the sensor. Various wall types (brick, concrete, dividing and hollow brickwork) have different behaviours with regard to thermal variations. A solid concrete wall responds to thermal fluctuations within a room in a much slower way than a light-weight structure wall. Room temperature sensors installed in flush boxes have a longer response time to thermal variations. In extreme cases they detect the radiant heat of the wall even if the air temperature in the room is lower for example. The quicker the dynamics of the wall (temperature acceptance of the wall) or the longer the selected inquiry interval of the temperature sensor is the smaller the deviations limited in time are.

## » BUILD-UP OF SELF-HEATING BY ELECTRICAL DISSIPATIVE POWER

Temperature sensors with electronic components always have a dissipative power, which affects the temperature measurement of the ambient air. The power dissipation occurring in active temperature sensors varies with the connected supply voltage. This dissipative power has to be considered when measuring temperature. In case of a fixed operating voltage ( $\pm 0,2$  V) this is normally done by adding or reducing a constant offset value. As Thermokon transducers work with a variable operating voltage, only one operating voltage can be taken into consideration, for reasons of production engineering. Transducers 0..10 V / 4..20 mA have a standard setting at an operating voltage of 24 V =. That means, that at this voltage, the expected measuring error of the output signal will be the least. For other operating voltages, the offset error will be increased by a changing power loss of the sensor electronics. If a re-calibration should become necessary later directly on the sensor, this can be done by means of the NOVOSapp software and an optional Bluetooth interface. (additionally with sensors with BUS interface via an appropriate software variable).

**Remark: Occurring draft leads to a better carrying-off of dissipative power at the sensor. Thus temporally limited fluctuations might occur upon temperature measurement.**

## » APPLICATION NOTICE FOR HUMIDITY SENSORS

Refrain from touching the sensitive humidity sensor/element. Touching the sensitive surface will void warranty.

For standard environmental conditions re-calibration is recommended once a year to maintain the specified accuracy.

When exposed to high ambient temperature and/or high levels of humidity or presence of aggressive gases (i.e. chlorine, ozone, ammonia) the sensor element may be affected and re-calibration may be required sooner than specified. Re-calibration and deterioration of the humidity sensor due to environmental conditions are not subject of the general warranty.

## » INFORMATION ABOUT SELF-CALIBRATION FEATURE CO2

Virtually all gas sensors are subject to some sort of drift. The degree of drift is partially dependent on the use of quality components and good design. But even with good components and excellent design, a small amount of drift can still occur in the sensor that may ultimately result in the need for a sensor to be recalibrated. The natural drift of the sensor is caused by:

- Dust/dirt
- Aggressive chemicals absorbed inside chamber / optical elements
- Corrosion inside chamber (high rh, condensation)
- Temperature cycles causing mechanical stress
- Electron/hole migration in the photo detector's semiconductor
- Drift of photo amplifiers
- External mechanical stress on chamber
- Light source wear-off

Most of the effects listed above will be compensated by the automatic self-calibration of the sensor's dual channel technology. In contrast to commonly used ABC-Logic self-calibrating sensors with dual channel technology are suitable for all applications including those operating 24 hours, 7 days a week, for example hospitals. However some effects cannot be compensated automatically and may result in a very gradual natural drift of a few ppm per month. This natural drift is not covered by Thermokon's 5-year warranty.

## » INFORMATION ABOUT INDOOR AIR QUALITY CO<sub>2</sub>

EN 13779 defines several classes for indoor air quality:

Category	CO <sub>2</sub> content above the content in outdoor air in ppm		Description
	Typical range	Standard value	
IDA1	<400 ppm	350 ppm	Good indoor air quality
IDA2	400.. 600 ppm	500 ppm	Standard indoor air quality
IDA3	600..1.000 ppm	800 ppm	Moderate indoor air quality
IDA4	>1.000 ppm	1.200 ppm	Poor indoor air quality

## » APPLICATION NOTICE FOR AIR QUALITY SENSORS VOC

Unlike CO<sub>2</sub> sensors, which specifically measure CO<sub>2</sub>, mixed gas sensors detect a wide range of gases. The sensor signal does not indicate the type of gas or its concentration in ppm. Mixed gas sensors detect gases and vapours consisting of carbohydrates, or more generally gases that can be oxidised (burnt): Odours, perfume, cleaning fluid scent, tobacco smoke, new materials fumigations (furniture, carpets, paint, glue ...).

Unlike CO<sub>2</sub>, which humans cannot sense, the amount of odours (VOC) indicates the level of air quality. VOC sensors have proven their value in a multitude of applications for many years.

### Measuring principle:

A heated tin dioxide semiconductor sensor burns (oxidizes) organic molecules that come into contact with it, thereby changing the resistance of the semiconductor. The change in resistance is characteristic for the type and concentration of the molecules. Gas mixtures such as air produce a mixed signal that can not be deduced from individual components. CO<sub>2</sub> can not be detected because it can not be burned.

**Refrain from touching the sensor's element sensitive surface. Touching the sensitive surface element will void warranty.**

## » INFORMATION ABOUT CALIBRATION VOC

Similar to a catalyst, the sensitivity of the sensor decreases over time. The VOC sensor compensates for this decrease in sensitivity through regular auto-calibration.

The measured values are recorded over a period of 24 hours. The lowest value within this period is used as the reference value ("new zero level") for clean, fresh air. Measured thereafter, lower readings result in an immediate adjustment of the reference value.

## » PRODUCT TESTING AND CERTIFICATION



### Declaration of conformity

The declaration of conformity of the products can be found on our website <https://www.thermokon.de/>.

## » TECHNICAL DATA

Measuring values (optional)	temperature, optional humidity   CO2   VOC
Network technology	RS485 Modbus, RTU, half-duplex, Baud rate 4800 9600 14400 19200 38400 56000 57600 or 115200 Parity: none (2 stopbits), even or odd (1 stopbit)
Power supply	24 V = ( $\pm 10\%$ ) or 24 V ~ ( $\pm 10\%$ ) SELV <i>With alternating voltage, the correct polarity must be ensured.<sup>1</sup></i>
Power consumption	typ. 2,5 W (24 V =)   5 VA (24 V ~)
Measuring range temp	-50..+50 °C   0..+50 °C   -15..+35   -20..+80 °C, default setting: 0..+50 °C, optionally configurable via Thermokon NOVOSapp or BUS
Accuracy temperature	$\pm 0,5K$ (typ. at 21 °C)
Inputs	1x input for floating contact
Control functions	occupancy signalling, light ON/OFF/DIM, setup scenarios, blinds UP/DOWN/SET, fan stages, setpoint, ECO function, measured value display & history
Display	TFT 4,8", 1120x480 px, capacitive touch technology
Enclosure	PC V0, pure white, Design surface glass Colour enclosure: pure white, black or aluminium, design panel: glass, white or black
Protection	IP30 according to DIN EN 60529
Cable entry	rear entry, breaking points bottom, drill mark top
Connection electrical	tool-free mountable spring terminal, max. 1,5 mm <sup>2</sup>
Ambient condition	0..+50 °C, max. 85% non-condensing
Mounting	surface mounted on flush-mounting box ( $\varnothing=60$ mm) or to be mounted flat onto the surface using screws, base part can be mounted and wired separately

<sup>1</sup>When several BUS devices are supplied by one 24 V AC voltage supply, it is to be ensured that all "positive" operating voltage input terminals (+) of the field devices are connected and all "negative" operating voltage input terminals (-) (=reference potential) are connected (in-phase connection of field devices). In the case of reversed polarity at one field device, a supply voltage short-circuit would be caused by that device.

The short-circuit current thus flowing through this field device will damage it. Therefore, pay attention to the correct wiring.

## Humidity (optional)

Measuring range humidity (optional configurable)	<b>relative humidity</b> 0..100% rH	<b>Enthalpy</b> 0..85 KJ/kg	<b>absolute humidity</b> 0..50   0..80 g/m <sup>3</sup>	<b>dew point</b> 0..+50   -20..+80 °C
	configurable via Thermokon NOVOSapp or BUS			
Accuracy humidity	$\pm 2\%$ between 10..90% rH (typ. at 21 °C)			

## CO2 (optional)

Measuring range CO2	0..2000   0..5000 ppm (configurable via Thermokon NOVOSapp or BUS)
Accuracy CO2	$\pm(50$ ppm +3 % of reading), (typ. at 21 °C, 50% rH, 1015 hPa)
Calibration	self-calibration dual channel
Sensor	NDIR (non-dispersive, infrared)

## VOC (optional)

Measuring range VOC	0..100 %
Calibration	self-calibration
Sensor	VOC sensor (heated metal oxide semiconductor)
Notes	mixed gas sensors detect gases and vapours which can be oxidised (burnt): Body odours, tobacco smoke, exhalations emitted by materials (furniture, carpets, paint, glue ...)

» CONNECTION PLAN

Room operating unit – active RS485 Modbus

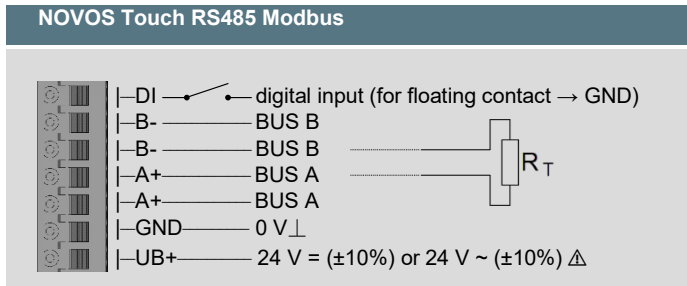

With alternating voltage, the correct polarity must be ensured!  
Please note the technical data.

Don't forget the BUS termination (120 Ω) at the last device of the line!  
(Not included in delivery)

» MOUNTING ADVICES

Cable entry

There are predetermined breaking points for 2 optional cable entries on the underside of the base plate.

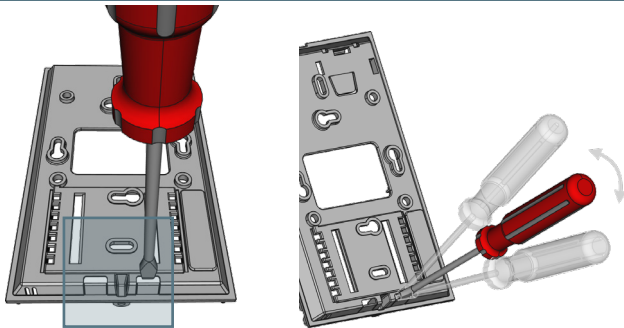

Please make sure that the device is de-energized if you want to install it!

The installation can be performed on the flat wall surface or on a flush-mounted box. A representative place should be selected. Sunshine and draft, e.g. in the installation tube should be avoided, so that the measurement result is not falsified. Seal the end of the installation tube.

- For wiring, the upper part of the device must be removed from the base plate. Base plate and upper part are detachably connected to each other by means of locking lugs.
- The mounting of the base plate on the flat wall surface is done with rawplugs and screws.
- Finally, the device is attached to the base plate and fixed with the screw.

Housing open / close

Snap the upper part of the housing into the locking lug on the upper side

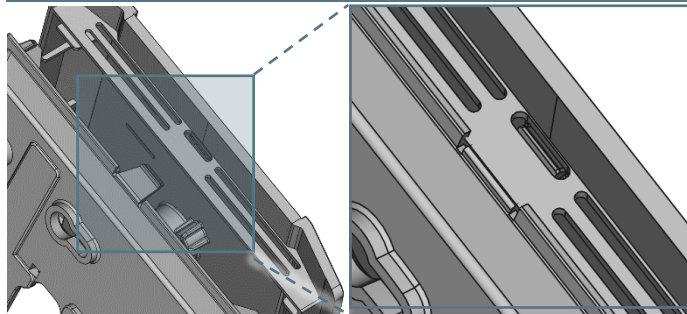

Fix the upper part of the housing on the underside with the screw included in the delivery.

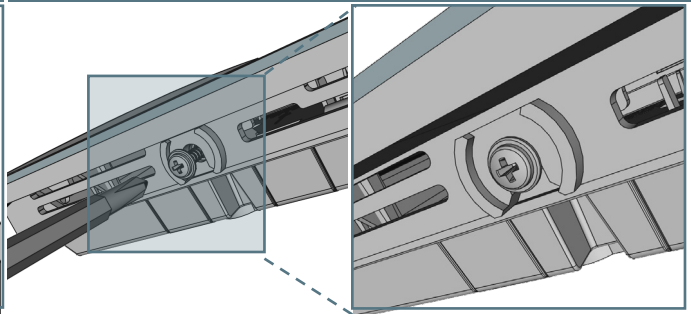

» FUNCTION DESCRIPTION – HOMESCREEN NOVOS TOUCH

**Home screen**  
The display on the main screen of the NOVOS room control unit can be freely parameterised. All icons and notifications can be switched on and off. Set point can also be overwritten.



**Headline**  
In the header of the main screen various icons can be shown or hidden as desired.

**Status messages**  
At any time, any text message (max. 24 characters) can be displayed on the main screen for status reporting or notification.

**Date / time**  
The time and date are in the center of the main screen.

**Favourite buttons**  
Light, scene groups or complete submenu can be placed on the home screen as a favourite button that is quickly accessible (if only one favorites key is used = favorite button 1) . Up to 4 favourite buttons (favourite buttons 2-5) are possible.

**Setpoint / room temperature**  
The currently set target value of the room control unit and the room temperature are shown on the display.

*Example below: 4 different Light circles (Favourite buttons 2-5)*

**Navigation bar**  
The navigation bar is a central element on the Home screen. It contains all menus such as climate, light, blinds, scene, monitoring, display ON/OFF and settings. If certain menus are not needed, they can be switched off as desired. With a swipe gesture you can scroll between the menu pages in the navigation bar.

To reduce the risk of burnt-in effects of the screen contents, it is recommended to activate the screen saver. By default, the screen saver switches on 120 seconds after the last interaction.



**Modbus addresses:**  
NOVOS-RS485 Modbus Interface

A detailed description of the Modbus addresses can be found under the following link:  
→ [Download](#)

» CONFIGURATION

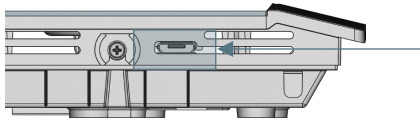

Position of the micro USB port, see bottom of the device, for configuration with Bluetooth dongle or Micro-USB programming interface

The configuration is performed in powered state. The following options are available for configuring the device:

<b>Device connection</b>	RS485	RS485	Micro-USB Prog. interface*	Micro-USB
<b>Configuration adapter</b>	USB-RS485 converter Item no. 668293	BMS	Item no. 597838	USB-Bluetooth Dongle* Item no. 668262
<b>Configuration interface</b>	PC/Notebook with uConfig software	BMS	PC/Notebook with uConfig software	Smartphone/Tablet with NOVOS App
	Parameterization via desktop PC/Notebook with uConfig software and a USB/RS485 converter (Item No. 668293).	Parameterization via building management System (BMS) using the RS485 Modbus network.	Parameterization via desktop PC/Notebook with uConfig software, via Micro RS-232/USB converter* (Item No. 597838).	Parameterization with mobile devices via Bluetooth and NOVOSapp. A separately available Bluetooth dongle* is required (item no. 668262).

\*Commercially available Bluetooth dongles or USB to Micro-USB adapter cables are not compatible. You need a mobile device that supports at least Bluetooth version 4.1. The configuration app with the corresponding instructions can be downloaded from the Google Play Store or the Apple App Store.

» DIMENSIONS (MM)

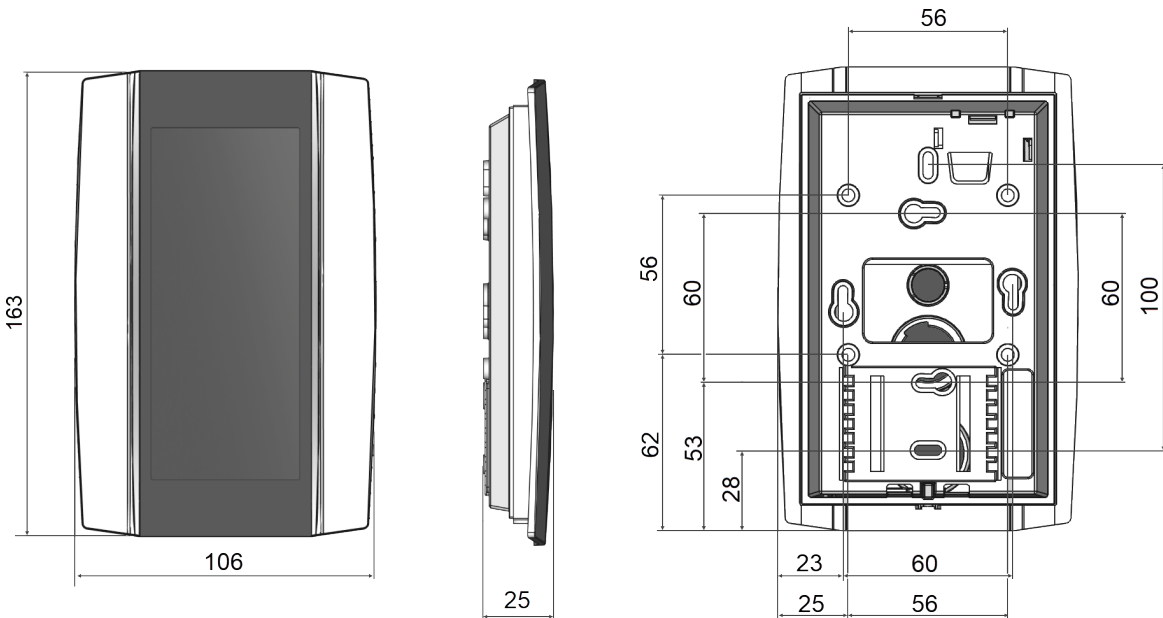

» ACCESSORIES (OPTIONAL)

- |  |                 |
|--|-----------------|
| Rawplugs and screws (2 pcs. each)  | Item No. 102209 |
| Bluetooth dongle   | Item No. 668262 |
| Converter RS485 Modbus-USB incl. Driver CD   | Item No. 668293 |
| PSU-UP24 – flush mount power supply 24 V (AC Input: 100..240 V ~   DC Output 24 V = 0,5 A) | Item No. 645737 |
| Programming interface, USB – Micro-USB   | Item No. 597838 |